

1953 Gallows Road, Suite 600

Vienna, VA 22182

(t) 703.734.5700

www.productionsolutions.com

For more industry news and updates, visit us on the Web at:
<http://www.productionsolutions.com/ps/newsroom/>

FIRST CLASS – LETTERS AND CARDS

Weight Not Over (Ounces)	Automation ¹				Non-Automation
	5-Digit	3-Digit	AADC	Mixed AADC	Presorted ²
1.0	0.376	0.399	0.399	0.419	0.662
2.0	0.376	0.399	0.399	0.419	0.662
3.0	0.626	0.649	0.649	0.669	0.912
3.5	0.751	0.774	0.774	0.794	1.037 ³
Postcard ⁴	0.250	0.263	0.263	0.272	—

¹ Subtract \$0.003 for each auto letter/card that complies with the full-service Intelligent Mail option requirements (effective 11/29/09).

² Letters that meet one or more of the non-machinable characteristics in DMM 201.2 are subject to the \$0.21 non-machinable surcharge.

³ The maximum weight for machinable letter preparation is 3.5 ounces.

⁴ The card price applies to each single or double postcard when originally mailed; reply half of double postcard-size mail piece must be designed for reply mail purposes only.

FIRST CLASS – FLATS

Weight Not Over (Ounces) ¹	Automation ²				Non-Automation
	5-Digit	3-Digit	ADC	Mixed ADC	Presorted
1.0	0.438	0.630	0.670	0.750	0.798
2.0	0.648	0.840	0.880	0.960	1.008
3.0	0.858	1.050	1.090	1.170	1.218
4.0	1.068	1.260	1.300	1.380	1.428
5.0	1.278	1.470	1.510	1.590	1.638
6.0	1.488	1.680	1.720	1.800	1.848
7.0	1.698	1.890	1.930	2.010	2.058

¹ Flat-size pieces with certain characteristics (see DMM 201.5) are subject to parcel prices.

² Subtract \$0.003 for each automation flat that complies with the full-service Intelligent Mail option requirements (effective 11/29/09).

FIRST CLASS – RETAIL LETTERS AND CARDS

Weight Not Over (Ounces)	Single-Piece Stamp ¹	Single-Piece Meter ¹
1.0	0.47	0.465
2.0	0.68	0.675
3.0	0.89	0.885
3.5 ²	1.10	1.095
Postcard ³	0.34	0.34

FIRST CLASS – RETAIL FLATS

Weight Not Over (Ounces) ⁴	Single Piece	Weight Not Over (Ounces) ⁴	Single Piece
1.0	0.94	6.0	1.99
2.0	1.15	7.0	2.20
3.0	1.36	8.0	2.41
4.0	1.57	9.0	2.62
5.0	1.78	10.0 ⁵	2.83

¹ Letters that meet one or more of the non-machinable characteristics in DMM 101.1.2 are subject to the \$0.21 non-machinable surcharge.

² For weights over 3.5 ounces, see flat-size prices.

³ The card price applies to each single or double postcard when originally marked; reply half of double postcard must be designed for reply mail purposes only.

⁴ Flat-size pieces with certain characteristics (see DMM 101.2.0) are subject to parcel prices.

⁵ Single-Piece Additional Ounce Rate (Letters/Flats): \$0.21.

DIMENSION INFORMATION

Card Dimensions

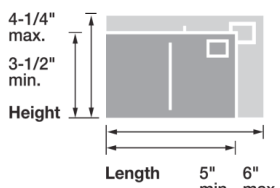

Measurement	Minimum	Maximum
Length	5 inches	6 inches
Height	3-½ inches	4-¼ inches
Thickness	0.007 inch	0.016 inch

Letter Dimensions ¹

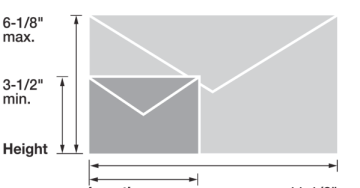

Measurement	Minimum	Maximum
Length	5 inches	11-½ inches
Height	3-½ inches	6-⅞ inches
Thickness	0.007 inch*	0.25 inch

*Min. is 0.009 inches if card is more than 4-¼ inches high or 6 inches long.

Flat Dimensions

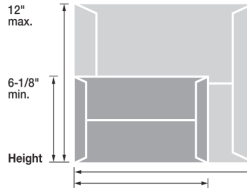

Measurement	Minimum*	Maximum
Length	11-½ inches	15 inches
Height	6-⅞ inches	12 inches
Thickness	0.25 inch	0.75 inch

*Flats exceed at least one of these dimensions.
 **Automated Flat Minimums: 6.0 inches L, 5.0 inches H & .009 inches T

ASPECT RATIO

The dimension of a mail piece expressed as a ratio of length (direction parallel to the address) divided by height.

For example:
 A postcard that is 5-½ inches long by 3-½ inches high has an aspect ratio of 1.57.

An aspect ratio between 1.3 and 2.5 is required for automation compatibility.

¹ Effective January 6th, 2014, folded self-mailers must comply with the following characteristics:

- Length: 5 inches minimum and 10-½ inches maximum.
- Height: 3-½ inches minimum and 6 inches maximum.
- Weight: 3 ounces maximum.
- Thickness and aspect ratio are the same as listed above.

STANDARD MAIL – NON-PROFIT LETTERS

	Entry Discount	Automation ^{1,2}				Non-Automation Presorted	
		5-Digit	3-Digit	AADC	Mixed AADC	AADC	Mixed AADC
Letters weighing between 3.3-3.5 ounces (Per-piece price)	None	0.140	0.159	0.159	0.176	0.175	0.192
	DNDC	0.105	0.124	0.124	0.141	0.140	0.157
	DSCF	0.096	0.115	0.115	—	0.131	—
	DDU	—	—	—	—	—	—

STANDARD MAIL – COMMERCIAL LETTERS

	Entry Discount	Automation ^{1,2}				Non-Automation Presorted	
		5-Digit	3-Digit	AADC	Mixed AADC	AADC	Mixed AADC
Letters weighing between 3.3-3.5 ounces (Per-piece price)	None	0.255	0.274	0.274	0.291	0.290	0.307
	DNDC	0.220	0.239	0.239	0.256	0.255	0.272
	DSCF	0.211	0.230	0.230	—	0.246	—
	DDU	—	—	—	—	—	—

1 Letters that are not automation-compatible and barcoded (DMM 201.3.0) may be mailable at the flat-size prices (DMM 243.6).

2 Subtract \$0.001 for each letter that complies with the full-service Intelligent Mail option requirements (effective 11/29/09).

STANDARD MAIL – NON-PROFIT FLATS

	Entry Discount	Automation ^{1,2}						Non-Automation Presorted ¹					
		FSS Scheme Pallet	FSS Other Pallet	5-Digit	3-Digit	ADC	Mixed ADC	FSS Scheme Pallet	FSS Other Pallet	5-Digit	3-Digit	ADC	Mixed ADC
Flats weighing 3.3 ounces or less (Per-piece price)	None	0.162	0.192	0.237	0.328	0.383	0.400	0.266	0.271	0.286	0.355	0.407	0.441
	DNDC	0.129	0.159	0.204	0.295	0.350	0.367	0.233	0.238	0.253	0.322	0.374	0.408
	DSCF	0.119	0.149	0.194	0.285	0.340	—	0.223	0.228	0.243	0.312	0.364	—
	DFSS	0.114	0.144	—	—	—	—	0.218	0.223	—	—	—	—
	DDU	—	—	—	—	—	—	—	—	—	—	—	—
Flats weighing more than 3.3 ounces ³ (Per-pound price)	None	0.660	0.660	0.660	0.660	0.660	0.660	0.660	0.660	0.660	0.660	0.660	0.660
	DNDC	0.499	0.499	0.499	0.499	0.499	0.499	0.499	0.499	0.499	0.499	0.499	0.499
	DSCF	0.451	0.451	0.451	0.451	0.451	—	0.451	0.451	0.451	0.451	0.451	—
	DFSS	0.451	0.451	—	—	—	—	0.451	0.451	—	—	—	—
	DDU	—	—	—	—	—	—	—	—	—	—	—	—
+ Per-piece rate	None	+0.026	+0.056	+0.101	+0.192	+0.247	+0.264	+0.130	+0.135	+0.150	+0.219	+0.271	+0.305
+ Per-piece rate	DNDC	+0.026	+0.056	+0.101	+0.192	+0.247	+0.264	+0.130	+0.135	+0.150	+0.219	+0.271	+0.305
+ Per-piece rate	DSCF	+0.026	+0.056	+0.101	+0.192	+0.247	—	+0.130	+0.135	+0.150	+0.219	+0.271	—
+ Per-piece rate	DFSS	+0.021	+0.051	—	—	—	—	+0.125	+0.130	—	—	—	—
+ Per-piece rate	DDU	—	—	—	—	—	—	—	—	—	—	—	—

STANDARD MAIL – COMMERCIAL FLATS

	Entry Discount	Automation ^{1,2}						Non-Automation Presorted ¹					
		FSS Scheme Pallet	FSS Other Pallet	5-Digit	3-Digit	ADC	Mixed ADC	FSS Scheme Pallet	FSS Other Pallet	5-Digit	3-Digit	ADC	Mixed ADC
Flats weighing 3.3 ounces or less (Per-piece price)	None	0.301	0.331	0.376	0.467	0.522	0.539	0.405	0.410	0.425	0.494	0.546	0.580
	DNDC	0.268	0.298	0.343	0.434	0.489	0.506	0.372	0.377	0.392	0.461	0.513	0.547
	DSCF	0.258	0.288	0.333	0.424	0.479	—	0.362	0.367	0.382	0.451	0.503	—
	DFSS	0.253	0.283	—	—	—	—	0.357	0.362	—	—	—	—
	DDU	—	—	—	—	—	—	—	—	—	—	—	—
Flats weighing more than 3.3 ounces ³ (Per-pound price)	None	0.763	0.763	0.763	0.763	0.763	0.763	0.763	0.763	0.763	0.763	0.763	0.763
	DNDC	0.602	0.602	0.602	0.602	0.602	0.602	0.602	0.602	0.602	0.602	0.602	0.602
	DSCF	0.554	0.554	0.554	0.554	0.554	—	0.554	0.554	0.554	0.554	0.554	—
	DFSS	0.554	0.554	—	—	—	—	0.554	0.554	—	—	—	—
	DDU	—	—	—	—	—	—	—	—	—	—	—	—
+ Per-piece rate	None	+0.144	+0.174	+0.219	+0.310	+0.365	+0.382	+0.248	+0.253	+0.268	+0.337	+0.389	+0.423
+ Per-piece rate	DNDC	+0.144	+0.174	+0.219	+0.310	+0.365	+0.382	+0.248	+0.253	+0.268	+0.337	+0.389	+0.423
+ Per-piece rate	DSCF	+0.144	+0.174	+0.219	+0.310	+0.365	—	+0.248	+0.253	+0.268	+0.337	+0.389	—
+ Per-piece rate	DFSS	+0.139	+0.169	—	—	—	—	+0.243	+0.248	—	—	—	—
+ Per-piece rate	DDU	—	—	—	—	—	—	—	—	—	—	—	—

1 Flat-size pieces with certain characteristics (see DMM 201.5) are subject to parcel prices.

2 Subtract \$0.001 for each letter that complies with the full-service Intelligent Mail option requirements (effective 11/29/09).

3 For pieces weighing more than 3.3 ounces, each piece is subject to both a per-piece price and a per-pound price. Multiply the number of pieces in the mailing by per-piece price. Multiply the number of pounds in the mailing by per-pound price. Add both totals.